

## Features

Patented structure, low air leakage rate



American Pro patented design of labyrinth seal structure which provides low air leakage formed by using aluminum sections with concave and convex chamfer at joints of AHU body and tightening with bolts and nuts.

Robust structural design



American Pro labyrinth AHU has an aluminum alloy frame and a hidden metal inner frame, in which the former constitutes a rigid body with high resistance to torsion by using a tenon structure and tightening with bolts and nuts, while the latter greatly improves the strength of the unit.

Flat interior, applicable for purification applications



American Pro labyrinth AHU is flat interiorly and has no insulation strips, seals and small cumbersome parts, making it ideal for purifying air conditioning and IAQ. The inner panel can be of hot dip galvanized panel, color panel or stainless steel panel.

Prevention of cold bridge and rust



All metals inside labyrinth AHU are isolated from those outside by means of polyurethane foaming and specially designed seals, eliminating insulation strips commonly used in general AHUs and therefore preventing the cold bridge. Frames of aluminum sections are embedded around all panels, completely isolating corners of metal panel from air and moisture and thereby preventing rust spot on panels.

Leveling device



A leveling device is provided on the base, which levels individual AHU body before connecting functional sections of two AHUs, ensuring seamless connection of AHUs.

Professional selection software



American Pro's AHUs are selected by professional selection software which is programmed in strict accordance with laws of engineering and modified according to actual service to provide more reliable software.

## Nomenclature

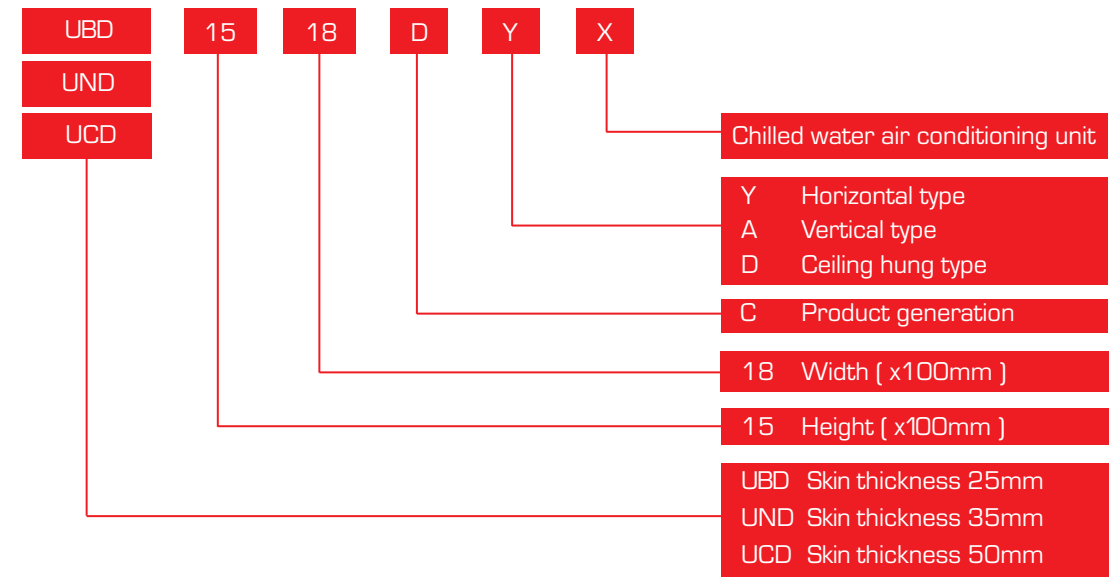

Example:

UCD 2224 CHW

Skin thickness = 50mm, Panel height = 22 x 100mm, Panel width = 24 x 100mm,

Horizontal type

Unit total height = Panel height + U + Base height

Unit total width = Panel width + U

For UBD, U = 50mm      UND, U = 70mm      UCD, U = 100mm

Base height = 80mm except when Panel height > 2500mm or Panel width > 2500mm

Base height = 100mm

## Method To Determine The Side Of Unit

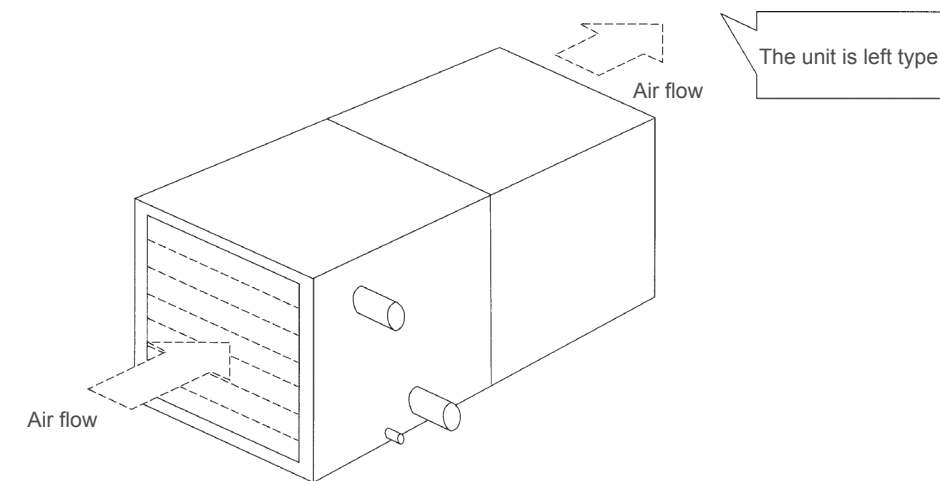

Facing the air flow, if water piping at left side indicates left type. Otherwise, right type.

# Air Flow Chart

UBD/ UND/ UCD		Coil Face Velocity(m/s)						Unit in m3/h
		2.00	2.25	2.50	2.80	3.00	3.50	
06	07	1567	1762	1958	2193	2351	2742	
06	08	1790	2014	2238	2506	2685	3133	
06	09	2207	2783	2758	3089	3311	3862	
06	10	2527	2843	3158	3537	3791	4422	
07	10	2888	3249	3610	4043	4332	5054	
07	11	3253	3660	4067	4555	4880	5693	
08	10	3610	4061	4512	5053	5415	6318	
08	11	4067	4575	5083	5964	6101	7117	
08	12	4524	5089	5655	6334	6786	7917	
08	13	4981	5604	6226	6974	7472	8717	
08	14	5438	6118	6798	7614	8157	9517	
10	12	5881	6616	7351	8234	8822	10292	
10	13	6476	7285	8094	9066	9714	11333	
10	15	7664	8622	9580	10730	11496	13412	
10	16	8259	9291	10323	11562	12389	14453	
11	15	8843	9949	11054	12381	13265	15475	
11	16	9529	10720	11911	13341	14294	16676	
11	17	10215	11492	12769	14301	15323	17876	
12	17	10896	12258	13620	15254	16344	19068	
12	18	11628	13081	14534	16279	17442	20349	
13	17	12258	13790	15322	17161	18387	21452	
13	18	13081	14716	16351	18313	19622	22892	
13	19	13904	15642	17380	19465	20856	24332	
14	19	14676	16511	18345	20547	22014	25683	
14	20	15545	17488	19431	21763	23318	27204	
15	19	16221	18249	20277	22710	24332	28387	
15	21	18141	20409	22677	25398	27212	31747	
16	21	19005	21381	23757	26607	28508	33259	
16	22	20011	22513	25014	28016	30017	35019	
16	24	22023	24776	27529	30832	33035	38540	
19	22	24559	27629	30699	34383	36839	42978	
19	23	25794	29018	32242	36111	38691	45140	
19	25	28263	31795	35328	39568	42395	49460	
20	25	29309	32973	36637	41033	43964	51291	
20	26	30589	34413	38237	42825	45884	53531	
21	26	32774	36871	40968	45884	49161	57355	
22	27	33866	38099	42333	47412	50799	59266	
23	26	36052	40558	45065	50473	54078	63091	
22	30	39536	44478	49420	55351	59304	69188	
25	28	42621	47949	53276	59670	63932	74587	
25	31	47559	53504	59449	66582	71339	83228	
25	34	52497	59059	62621	73495	78746	91870	
28	34	59788	67261	74735	83703	89682	104629	
28	38	67286	75697	84107	94200	100929	117751	
29	40	72767	81863	90959	101874	109151	127342	
31	41	79292	89204	99115	111009	118938	138761	
32	45	89467	100650	111833	125253	134201	156567	
35	46	101523	114213	126904	142432	152285	177665	
37	50	117371	132042	146713	164319	176057	205399	
38	55	136921	154037	171152	191690	205382	239612	
43	58	165054	185685	206317	231075	247581		
45	65	191575	215522	239469	268205	280000		

# Length Of Functional Sections

UBD/ UND/ UCD		Length (mm)														Others
		Mixing Box	Fresh Air and Exhaust Air	Plate Filter	Bag Filter	Rigid Filter	Cooling Coil (1R - 4R)	Cooling Coil (5R - 6R)	Cooling Coil (8R - 12R)	Heating Coil	Access	Sound Attenuator	Fan (Type A)	Fan (Type B)		
06	07	600	1200	100	400	400	600	700	900	300	600	800	900(200)	1100(225)		
06	08	600	1200	100	400	400	600	700	900	300	600	800	900(200)	1100(225)		
06	09	600	1200	100	400	400	600	700	900	300	600	800	700(200)	1200(280)		
06	10	600	1200	100	400	400	600	700	900	300	600	800	700(200)	1300(315)		
07	10	600	1200	100	400	400	600	700	900	300	600	800	700(200)	1300(315)		
07	11	600	1200	100	400	400	600	700	900	300	600	800	800(225)	1300(315)		
08	10	600	1200	100	400	400	600	700	900	300	600	800	700(200)	1300(315)		
08	11	600	1200	100	400	400	600	700	900	300	600	800	800(225)	1300(315)		
08	12	600	1200	100	400	400	600	700	900	300	600	800	800(315)			
08	13	600	1200	100	400	400	600	700	900	300	600	800	800(315)			
08	14	600	1200	100	400	400	600	700	900	300	600	800	800(315)			
10	12	600	1200	100	400	400	600	700	900	300	600	800	800(315)	1500(400)		
10	13	600	1200	100	400	400	600	700	900	300	600	800	900(335)	1500(400)		
10	15	600	1200	100	400	400	600	700	900	300	600	800	900(335)	1500(400)		
10	16	600	1200	100	400	400	600	700	900	300	600	800	900(335)	1500(400)		
11	15	600	1200	100	400	400	600	700	900	300	600	800	1000(400)	1800(500)		
11	16	600	1200	100	400	400	600	700	900	300	600	800	1000(400)	1800(500)		
11	17	600	1200	100	400	400	600	700	900	300	600	800	1100(450)	1800(500)		
12	17	800	1200	100	400	400	600	700	900	300	600	800	1100(450)			
12	18	800	1200	100	400	400	600	700	900	300	600	800	1100(450)	1200(500)		
13	17	800	1200	100	400	400	600	700	900	300	600	800	1100(450)			
13	18	800	1200	100	400	400	600	700	900	300	600	800	1100(450)	1200(500)		
13	19	800	1200	100	400	400	600	700	900	300	600	800	1100(450)	1300(560)		
14	19	800	1200	100	400	400	600	700	900	300	600	800	1200(500)	1300(560)		
14	20	800	1200	100	400	400	600	700	900	300	600	800	1200(500)	1300(560)		
15	19	800	1200	100	400	400	600	700	900	300	600	800	1200(500)	1300(560)		
15	21	800	1200	100	400	400	600	700	900	300	600	800	1300(560)	1500(630)		
16	21	800	1200	100	400	400	600	700	900	300	600	800	1300(560)	1500(630)		
16	22	800	1200	100	400	400	600	700	900	300	600	800	1300(560)	1500(630)		
16	24	800	1200	100	400	400	600	700	900	300	600	800	1300(560)	1700(710)		
19	22	800	1200	100	400	400	600	700	900	300	600	800	1500(630)	2600(800)		
19	23	800	1200	100	400	400	600	700	900	300	600	800	1500(630)	2600(800)		
19	25	800	1200	100	400	400	600	700	900	300	600	800	1700(710)	2600(800)		
20	25	800	1500	100	400	400	600	700	900	300	600	800	1700(710)	2600(800)		
20	26	800	1500	100	400	400	600	700	900	300	600	800	1800(800)	3000(900)		
21	26	800	1500	100	400	400	600	700	900	300	600	800	1800(800)	3000(900)		
22	27	1000	1500	100	400	400	600	700	900	300	600	800	2100(900)	3300(1000)		
22	30	1000	1500	100	400	400	600	700	900	300	600	800	2100(900)	3300(1000)		
23	26	1000	1500	100	400	400	600	700	900	300	600	800	1800(800)	3000(900)		
25	28	1000	1500	100	400	400	600	700	900	300	600	800	2100(900)	3300(1000)		
25	31	1000	1500	100	400	400	600	700	900	300	600	800	2100(900)	2200(1000)		
25	34	1000	1500	100	400	400	600	700	900	300	600	800	2100(900)	2200(1000)		
28	34	1200	1500	100	400	400	600	700	900	300	600	800	2100(900)	2200(1000)		
28	38	1200	1500	100	400	400	600	700	900	300	600	800	2600(800*2)			
29	40	1200	1500	100	400	400	600	700	900	300	600	800	2600(800*2)			
31	41	1200	1800	100	400	400	1000	1000	1200	600	600	800	2600(800*2)			
32	45	1200	1800	100	400	400	1000	1000	1200	600	600	800	2800(900*2)			
35	46	1200	1800	100	400	400	1000	1000	1200	600	600	800	3300(1000*2)			
37	50	1200	1800	100	400	400	1000	1000	1200	600	600	800	3300(1000*2)			
38	55	1200	1800	100	400	400	1000	1000	1200	600	600	800	3400(1120*2)			
43	58	1200	1800	100	400	400	1000	1000	1200	600	600	800	3400(1120*2)			
45	65	1200	1800	100	400	400	1000	1000	1200	600	600	800	3500(1250*2)			

Length of Heat Recovery and De-humidifier Section is based on actual selection. Gas Heater Section:3000. Activated Carbon Section:100-500.

Note :1. Unit total length is equal to the summation of all sections.  
 2. The length as listed above is for reference only. Actual dimension may vary due to actual application and design.



### Comparison of purification and sterilization technologies

Sterilization Method	Ability of Dust Removal	Ability of Killing Bacteria and Viruses	Ability of Removing Formaldehyde, Benzene and TVOC
Electronic purification	☆	☆	
Activated carbon			☆
Ultraviolet lamp		☆	
Photocatalyst		☆	
Ozone generator		☆	
Traditional plate/bag filter	☆		

– strong, space - without

### Comparison of purification and sterilization technologies in installation and maintenance.

1M=100mm

Sterilization Method	Length of Functional Section	Power Supply	Replacement and Cleaning
Electronic purification	3M	220 V ~ 50 Hz	Cleaning once a year
Activated carbon	Plate: 1M, carbon box: 4M	220 V ~ 50 Hz	Plate: unwashable, carbon box: addition of carbon allowed
Ultraviolet lamp	0M, not occupying the section length	220 V ~ 50 Hz	No need for cleaning, continuous use
Photocatalyst	3M	220 V ~ 50 Hz	No need for cleaning, continuous use
Ozone generator	0M, located at air outlet section	220 V ~ 50 Hz	Cleaning once half a year
Traditional plate/bag filter	1M, 5M		Consumable

### Cooling Coil Performance Chart

UBD/UND/UCD	Air Flow m³/h	Fresh Air Condition						Return Air Condition						
		4 Rows		6 Rows		8 Rows		4 Rows		6 Rows		8 Rows		
		SC kW	TC kW	SC kW	TC kW	SC kW	TC kW	SC kW	TC kW	SC kW	TC kW	SC kW	TC kW	
06	07	1958	9	21	12	29	13	31	8	9	9	12	10	15
06	08	2238	11	24	14	33	15	36	9	11	10	14	11	17
06	09	2758	13	29	17	41	18	44	11	13	12	17	14	21
06	10	3158	15	33	19	46	21	50	12	15	14	19	16	24
07	10	3610	17	38	22	53	24	58	14	17	16	22	18	28
07	11	4067	19	43	25	60	27	65	16	20	18	25	21	31
08	10	4512	21	47	28	66	30	72	18	22	20	27	23	35
08	11	5083	24	53	31	75	34	81	20	24	22	31	26	39
08	12	5655	27	59	35	83	37	90	22	27	25	34	29	43
08	13	6226	29	66	38	92	41	99	24	30	27	38	31	48
08	14	6798	32	72	42	100	45	108	27	33	30	41	34	52
10	12	7351	35	77	45	108	49	117	29	35	32	45	37	56
10	13	8094	38	85	50	119	53	129	32	39	36	49	41	62
10	15	9580	45	101	59	141	63	153	37	46	42	58	48	73
10	16	10323	49	109	63	152	68	165	40	50	45	63	52	79
11	15	11054	52	116	68	163	73	176	43	53	49	67	56	85
11	16	11911	56	125	73	175	79	190	46	57	52	72	60	91
11	17	12769	60	134	78	188	84	204	50	61	56	78	64	98
12	17	13620	64	143	84	200	90	217	53	65	60	83	69	104
12	18	14534	69	153	89	214	96	232	57	70	64	88	73	111
13	17	15322	72	161	94	225	101	244	60	74	67	93	77	118
13	18	16351	77	172	100	241	108	261	64	79	72	99	82	125
13	19	17380	82	183	107	256	115	277	68	83	76	106	88	133
14	19	18345	87	193	113	270	121	293	72	88	81	111	93	141
14	20	19431	92	204	119	286	128	310	76	93	85	118	98	149
15	19	20277	96	213	124	298	134	324	79	97	89	123	102	156
15	21	22677	107	239	139	334	150	362	89	109	100	138	114	174
16	21	23757	112	250	146	350	157	379	93	114	104	144	120	182
16	22	25014	118	263	153	368	165	399	98	120	110	152	126	192
16	24	27529	130	290	169	405	182	439	107	132	121	167	139	211
19	22	30699	145	323	188	452	203	490	120	147	135	186	155	235
19	23	32242	152	339	198	474	213	514	126	155	142	196	163	247
19	25	35328	167	372	217	520	233	564	138	170	155	215	178	271
20	25	36637	173	385	225	539	242	585	143	176	161	222	185	281
20	26	38237	180	402	234	563	252	610	149	184	168	232	193	293
21	26	40968	193	431	251	603	270	654	160	197	180	249	207	314
22	27	42333	199	445	259	623	279	676	165	204	186	257	214	324
23	26	45065	212	474	276	663	297	719	176	216	198	274	227	346
22	30	49420	233	520	303	727	326	789	193	238	217	300	250	379
25	28	53276	251	560	327	784	352	850	208	256	234	324	269	409
25	31	59449	280	625	365	875	392	948	232	285	261	361	300	456
25	34	62621	309	690	402	965	433	1047	256	315	288	398	331	503
28	34	74735	352	786	458	1100	493	1192	292	359	328	454	377	573
28	38	84107	397	885	516	1237	555	1342	328	404	370	511	424	645
29	40	90959	429	957	558	1338	600	1451	355	437	400	552	459	698
31	41	99115	467	1043	608	1458	654	1581	387	476	435	602	500	760
32	45	111833	527	1177	686	1645	738	1784	436	537	491	679	564	858
35	46	126904	598	1335	778	1867	838	2025	495	609	558	771	640	973
37	50	146713	692	1543	900	2158	968	2341	573	705	645	891	740	1125
38	55	171152	807	1801	1050	2518	1130	2731	668	822	752	1039	863	1313
43	58	206317	973	2171	1265	3035	1362	3292	805	991	906	1253	1040	1582
45	65	239469	1129	2519	1468	3523	1581	3821	935	1150	1052	1454	1207	1837

Note:

- 1.Fresh Air Condition: entering air temperature 35°CDB/28°CWB.
- 2.Return Air Condition: entering air temperature 27°CDB/19.5°CWB.
- 3.Chilled water entering/leaving temperature, 7°C/12°C.Coil face velocity is 2.5m/s.
- 4.Manufacturer reserves the rights to change the data without prior notice.
- 5.Abbreviations:SC - Sensible Cooling Capacity,TC - Total Cooling Capacity.

# Heating Coil Performance Chart

UBD/UND/UCD		Air Flow m <sup>3</sup> /h	Fresh Air Condition				Return Air Condition			
			1Rows	2Rows	3Rows	4Rows	1Rows	2Rows	3Rows	4
			TH kW	TH kW	TH kW	TH kW	TH kW	TH kW	TH kW	TH kW
06	07	1958	12	18	23	26	9	14	19	
06	08	2238	14	20	26	30	10	16	21	24
06	09	2758	17	25	32	37	12	20	26	
06	10	3158	20	29	37	42	14	23	30	34
07	10	3610	23	33	42	48	16	26	34	
07	11	4067	26	37	47	54	18	29	39	44
08	10	4512	28	41	52	60	20	32	43	
08	11	5083	32	46	59	68	23	36	49	55
08	12	5655	36	52	65	75	25	41	54	
08	13	6226	39	57	72	83	28	45	59	68
08	14	6798	43	62	79	91	30	49	65	
10	12	7351	46	68	85	98	33	53	70	80
10	13	8094	51	74	94	108	36	58	77	
10	15	9580	60	87	111	128	42	69	91	105
10	16	10323	65	94	120	138	46	74	99	113
11	15	11054	70	101	128	147	49	79	106	121
11	16	11911	75	109	138	159	53	85	114	130
11	17	12769	81	116	148	170	57	91	122	139
12	17	13620	86	124	158	182	60	98	130	149
12	18	14534	92	133	168	194	64	104	139	159
13	17	15322	97	140	177	204	68	110	146	167
13	18	16351	103	149	189	218	72	117	156	178
13	19	17380	110	158	201	232	77	124	166	190
14	19	18345	116	167	212	245	81	131	175	200
14	20	19431	123	177	225	259	86	139	186	212
15	19	20277	128	185	235	270	90	145	194	221
15	21	22677	143	207	263	302	100	162	217	247
16	21	23757	150	217	275	317	105	170	227	259
16	22	25014	158	228	290	334	111	179	239	273
16	24	27529	174	251	319	367	122	197	263	300
19	22	30699	194	280	355	409	136	220	293	335
19	23	32242	204	294	373	430	143	231	308	352
19	25	35328	223	322	409	471	157	253	337	386
20	25	36637	231	334	424	488	162	262	350	400
20	26	38237	241	349	443	510	169	274	365	417
21	26	40968	259	374	474	546	182	293	391	447
22	27	42333	268	389	497	562	184	303	399	454
23	26	45065	284	411	522	601	200	323	430	492
22	30	49420	313	454	581	656	215	353	466	530
25	28	53276	336	486	617	710	236	382	509	581
25	31	59449	375	542	688	793	263	426	568	649
25	34	62621	414	598	760	875	291	470	627	716
28	34	74735	472	682	865	996	331	535	714	816
28	38	84107	531	767	974	1121	373	602	803	918
29	40	90959	574	829	1053	1213	403	652	869	993
31	41	99115	626	904	1148	1322	439	710	947	1082
32	45	111833	706	1020	1295	1491	496	801	1068	1220
35	46	126904	801	1157	1469	1692	562	909	1212	1385
37	50	146713	926	1338	1699	1956	650	1051	1401	1601
38	55	171152	1080	1561	1982	2282	758	1226	1635	1868
43	58	206317	1302	1881	2389	2751	914	1478	1970	2251
45	65	239469	1512	2184	2773	3193	1061	1715	2287	2613

- Note:  
 1.Fresh Air Condition: entering air temperature 7°CDB.  
 2.Return Air Condition: entering air temperature 15°CDB.  
 3.Hot water entering/leaving temperature,60°C/50°C.Coil face velocity is 2.5m/s.  
 4.Manufacturer reserves the rights to change the data without prior notice.  
 5.Abbreviations:TH - Total Heating Capacity.

## Weight - Fan, Motor and Accessories

Fan Model	Forward Curve	Backward Curve	Fan and Motor Installation Base Frame Weight
	kg	kg	
180	10	/	17.4
200	11	/	18
225	13	/	18.6
250	22	23	19.2
280	25	26	19.8
315	31	32	21.6
355	41	44	22.8
400	53	59	25
450	67	74	28
500	77	84	30
560	126	138	86
630	176	177	100
710	220	253	109
800	289	326	124
900	384	427	180
1000	450	518	204

Motor Power	Motor Weight	Motor Accessories Weight
kW	kg	kg
0.55	16	3
0.75	17	3
1.1	21	4
1.5	25	5
2.2	32	7
3	36	8
4	45	14
5.5	60	20
7.5	73	23
11	116	35
15	137	42
18.5	170	56
22	186	63
30	254	84
37	308	107
45	335	124
55	450	135
75	534	163



## Unit Weight (Cabinet Only)

UBD/UND/ UCD		Weight (kg)														
		Thickness25mm				Thickness35mm				Thickness50mm						
		Terminal Panel	300	600	900	1200	Terminal Panel	300	600	900	1200	Terminal Panel	300	600	900	1200
06	07	5	38	68	86	99	6	40	70	90	104	7	41	73	99	111
06	08	6	40	70	88	101	7	42	72	93	107	8	43	75	102	116
06	09	7	42	72	97	111	8	44	74	101	116	9	45	77	104	126
06	10	8	44	74	102	117	9	46	75	106	122	10	47	79	106	132
07	10	8	45	75	104	119	9	47	77	107	124	10	48	81	110	134
07	11	9	47	77	107	123	9	49	79	109	126	10	50	83	112	138
08	10	10	46	76	105	121	11	48	78	108	125	12	49	82	112	136
08	11	10	48	78	108	124	11	50	80	110	127	12	51	84	114	139
08	12	10	50	80	110	127	11	52	82	112	132	12	53	86	116	142
08	13	11	52	82	112	132	12	54	84	114	139	13	55	88	118	145
08	14	12	54	84	114	135	13	56	86	116	143	14	57	90	120	148
10	12	12	52	82	111	131	13	53	84	113	142	14	55	87	118	146
10	13	13	54	84	113	136	14	55	86	115	145	15	57	89	119	149
10	15	15	58	88	117	143	16	59	90	119	150	17	61	93	123	155
10	16	16	60	90	119	146	17	61	92	122	152	18	63	95	125	158
11	15	17	59	89	118	146	18	60	91	121	150	19	62	94	124	156
11	16	18	61	91	120	149	19	62	93	123	153	20	64	96	126	159
11	17	19	63	93	122	152	21	64	95	125	156	22	66	98	129	162
12	17	20	64	94	124	154	22	65	96	127	158	23	67	99	131	164
12	18	21	66	96	126	156	23	67	98	129	160	24	69	101	133	166
13	17	22	65	95	124	154	23	66	97	127	158	24	68	100	131	164
13	18	24	67	97	126	156	25	68	99	129	160	25	70	102	133	166
13	19	25	69	99	128	158	26	70	101	131	162	27	72	104	135	168
14	19	25	70	100	131	160	26	71	102	132	164	27	73	105	137	172
14	20	27	72	102	134	162	28	73	104	136	166	29	75	107	139	176
15	19	27	71	101	133	161	28	72	103	135	168	29	74	106	138	175
15	21	31	75	105	140	165	32	78	109	142	178	33	78	110	144	185
16	21	33	77	107	144	168	34	80	111	146	183	35	80	112	148	190
16	22	34	79	109	149	172	36	82	114	150	188	37	82	115	154	196
16	24	37	85	123	160	197	40	86	127	165	204	43	88	131	172	213
19	22	41	84	122	161	200	44	85	126	166	206	48	87	130	172	215
19	23	42	86	124	163	202	45	87	128	168	208	50	89	132	174	217
19	25	44	90	128	168	206	47	91	132	172	212	52	93	136	178	221
20	25	49	93	134	175	216	52	95	138	180	222	56	97	142	187	231
20	26	50	95	136	177	218	53	97	140	182	224	58	99	144	189	233
21	26	53	96	139	182	225	56	98	142	187	231	60	100	147	193	240
22	27	57	98	141	184	227	61	100	144	189	234	72	102	149	196	243
23	26	57	100	143	186	229	61	102	146	191	236	72	104	151	198	245
23	30	63	110	158	205	253	67	113	161	211	260	79	115	167	219	270
25	28	66	124	182	240	297	69	126	186	245	305	80	128	191	253	315
25	31	72	133	193	253	312	72	135	197	258	320	87	138	202	266	331
25	34	79	142	203	265	327	84	144	208	272	335	94	147	213	280	347
28	34	91	147	213	279	345	98	149	213	279	345	109	156	224	295	366
28	38	102	158	226	294	362	107	160	230	301	371	128	163	237	311	384
29	40	104	162	230	298	362	109	164	234	305	375	130	167	241	315	388
31	41	121	171	244	318	391	135	173	250	326	402	153	165	257	337	417
32	45	132	181	257	332	408	148	184	263	341	419	166	188	270	352	434
35	46	150	192	276	360	444	163	195	282	369	455	182	199	289	381	472
37	50	163	206	292	378	464	174	209	298	387	477	206	213	306	400	493
38	55	197	222	313	404	494	208	226	320	414	507	223	231	329	427	525
43	58	235	249	343	439	534	247	252	348	444	547	266	258	359	462	570
45	65	274	279	375	479	585	289	282	379	484	597	311	288	398	512	633

Example of weight calculation:

- 1.Total Weight of Cooling Coil Section = Cooling Section Cabinet Weight + Coils Weight
- 2.Total Weight of Fan Section = Fan Section Cabinet Weight + Fan Weight + Motor Weight + Motor Accessories Weight + Fan and Motor Base Frame Weight
- 3.Total Unit Weight = Sum of Weight for each Section + Panel Weight

## Unit Weight (Components Only)

UBD/UND/ UCD		Weight (kg)																				
		Damper-Mixing Box	Panel Filter	Bag Filter	Moisture Eliminator	Sound Attenuator	Wet Film Humidifier (Dry)								Standard 1/2" Coil (Without Water)							
							Thickness 50mm	Thickness 100mm	Thickness 150mm	Thickness 200mm	1 Rows	2 Rows	3 Rows	4 Rows	5 Rows	6 Rows	8 Rows	10 Rows	12 Rows			
06	07	11	4	4	5	15	7	8	10	11	15	19	21	23	25	28	32	37	41			
06	08	11	5	5	6	18	7	9	10	11	17	22	23	25	28	31	36	41	46			
06	09	15	5	5	7	20	8	9	11	13	17	22	24	26	30	33	39	45	50			
06	10	18	6	6	8	22	8	10	11	13	17	23	26	28	32	36	43	49	55			
07	10	18	6	7	10	26	8	10	12	14	19	26	29	32	36	40	47	54	61			
07	11	20	7	8	11	28	8	10	12	15	20	27	30	34	38	43	51	59	66			
08	10	18	7	8	12	29	9	11	13	15	23	31	34	38	43	48	57	66	74			
08	11	20	8	9	14	32	9	11	13	16	24	32	36	40	46	52	62	71	80			
08	12	22	9	10	15	35	9	12	14	17	25	34	38	43	49	55	66	76	86			
08	13	24	10	10	17	38	9	12	15	17	26	36	40	45	52	59	70	81	92			
08	14	26	10	11	19	41	10	12	15	18	27	37	42	48	55	62	75	86	98			
10	12	22	11	12	20	44	10	12	15	18	31	42	48	53	61	69	83	96	108			
10	13	24	12	13	22	48	10	13	16	19	32	44	50	56	65	73	88	102	116			
10	15	29	14	15	26	55	11	14	17	21	34	47	55	62	72	81	99	115	131			
10	16	31	15	16	28	59	11	14	18	22	35	49	57	65	75	86	104	121	139			
11	15	29	15	17	30	61	11	15	18	22	38	53	62	70	81	92	112	130	149			
11	16	31	16	18	33	65	11	15	19	23	39	55	64	73	85	97	118	138	158			
11	17	33	17	19	35	69	12	16	20	24	40	57	67	76	89	101	124	145	166			
12	17	48	19	21	37	75	12	16	20	25	43	60	71	81	94	107	131	154	176			
12	18	51	20	22	40	79	12	17	21	26	44	62	73	84	98	112	137	161	185			
13	17	48	20	22	42	81	12	17	21	26	47	66	78	89	104	119	145	171	196			
13	18	51	22	24	45	86	13	17	22	27	48	69	81	93	109	124	152	179	206			
13	19	54	23	25	48	91	13	18	23	28	49	71	84	97	113	130	159	188	216			
14	19	54	25	27	51	98	13	18	24	29	52	74	88	102	119	136	167	197	227			
14	20	58	26	28	54	103	14	19	24	30	53	76	91	105	124	142	174	206	238			
15	19	54	26	29	56	105	14	19	25	31	56	81	96	111	130	149	183	216	249			
15	21	61	29	32	63	116	14	20	26	33	59	86	102	119	140	161	199	235	272			
16	21	61	31	34	66	123	15	21	27	34	61	89	107	124	146	168	207	246	284			
16	22	64	33	35	69	129	15	21	28	35	63	92	110	129	151	174	215	256	296			
16	24	70	36	39	77	141	16	23	30	37	66	97	117	138	162	187	232	276	320			
19	22	64	39	42	85	153	16	24	31	39	75	109	132	155	182	209	260	309	358			
19	23	67	41	44	90	160	17															