

# SPECIFICATIONS

## AP.EDMD-N Technical Specifications

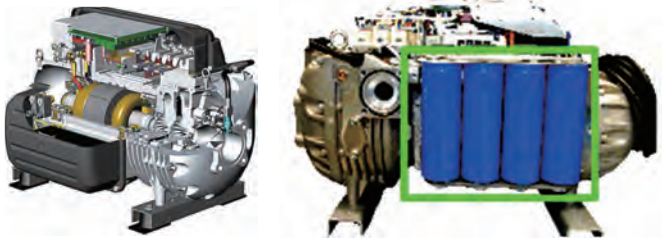

Model	COMPRESSORS		UNIT DIMENSIONS			UNIT WEIGHT	
	Model	Qty	Length	Width	Height	Operating	Shipping
			mm [inch]	mm [inch]	mm [inch]	kg [lbs]	kg [lbs]
AP.EDMD80NBT	TT300	1	2560 [100.9]	1110 [43.7]	2020 [79.4]	1924 [4242]	1618 [3567]
AP.EDMD120NDT	TT350	1	2680 [105.4]	1110 [43.7]	2020 [79.4]	2785 [6140]	2517 [5549]
AP.EDMD150NET	TT400	1	3970 [156.3]	1120 [44.0]	2020 [79.4]	2931 [6462]	2629 [5796]
AP.EDMD200NGT	TT700	1	3970 [156.3]	1120 [44.0]	2020 [79.4]	2938 [6477]	2636 [5811]
AP.EDMD240NDE	TT350	2	4070 [160.0]	1100 [43.2]	2020 [79.4]	3780 [8333]	3404 [7505]
AP.EDMD300NEE	TT400	2	3890 [153.0]	1210 [47.7]	2140 [84.3]	4770 [10516]	4284 [9445]
AP.EDMD400NGE	TT700	2	4220 [165.9]	1210 [47.7]	2140 [84.3]	4784 [10547]	4298 [9475]
AP.EDMD450NEU	TT400	3	4330 [170.5]	1920 [75.3]	2080 [81.8]	6253 [13786]	5583 [12308]
AP.EDMD600NGU	TT700	3	4390 [172.6]	2050 [80.6]	2190 [86.2]	7572 [16693]	6744 [14868]
AP.EDMD800NGG	TT700	4	4950 [194.7]	2120 [83.3]	2210 [87.0]	9761 [21519]	8596 [18951]

# DIMENSIONS

## Unit Dimensions

### Single Compressor

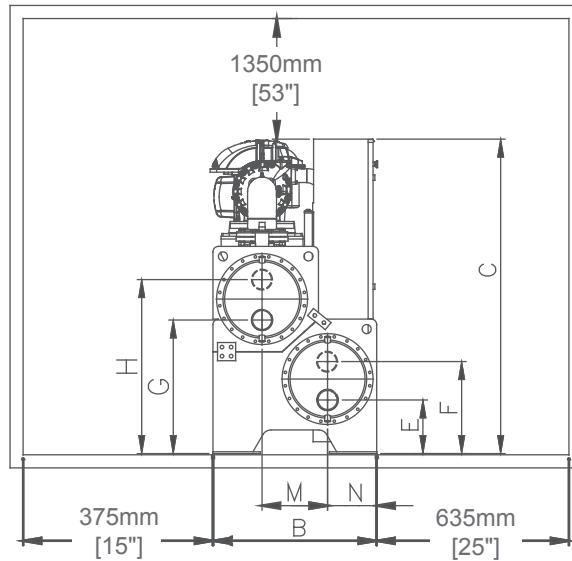
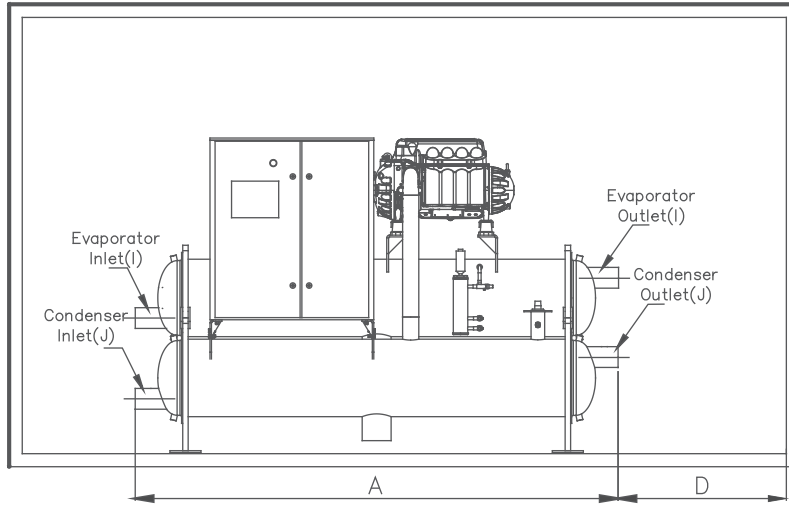

Model	Length "A"	Width "B"	Height "C"	Clearance For Tube Cleaning "D"	E	F	G	H	M	N	Condenser Water Conn. "J"	Evaporator Water Conn. "I"
	mm [inch]											
AP.EDMD80NBT	2560 [100.8]	1110 [43.7]	2020 [79.4]	2200 [86.6]	278 [11.0]	558 [22.0]	860 [33.9]	1164 [45.8]	349 [13.7]	315 [12.4]	5" NPS	5" NPS
AP.EDMD120NDT	2680 [105.4]	1110 [43.7]	2020 [79.4]	2200 [86.6]	307 [12.1]	618 [24.3]	886 [34.9]	1229 [48.4]	365 [14.4]	315 [12.4]	5" NPS	5" NPS
AP.EDMD150NET	3970 [156.3]	1120 [44.0]	2020 [79.4]	3400 [133.9]	296 [11.7]	629 [24.8]	886 [34.9]	1229 [48.4]	365 [14.4]	315 [12.4]	6" NPS	6" NPS
AP.EDMD200NGT	3970 [156.3]	1120 [44.0]	2020 [79.4]	3400 [133.9]	296 [11.7]	629 [24.8]	886 [34.9]	1229 [48.4]	365 [14.4]	315 [12.4]	6" NPS	6" NPS

Notes: 1) Above dimensions are based on standard unit, with 3 passes evaporator and condenser, 1.0MPa [150psi] water side service pressure.  
 2) Unit layout shown are for a reference. Same orientation may vary.  
 3) Certified drawings are available upon request.

## Unit Dimensions

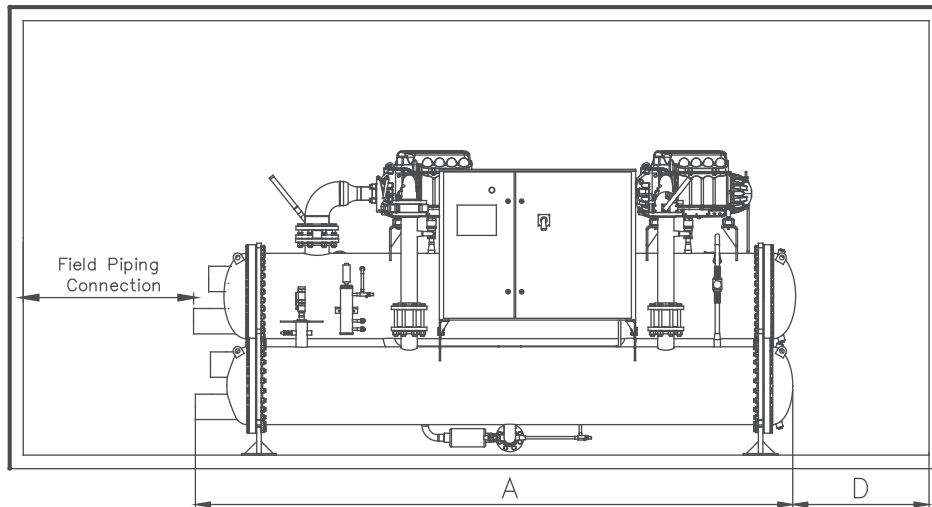

## Twin Compressors

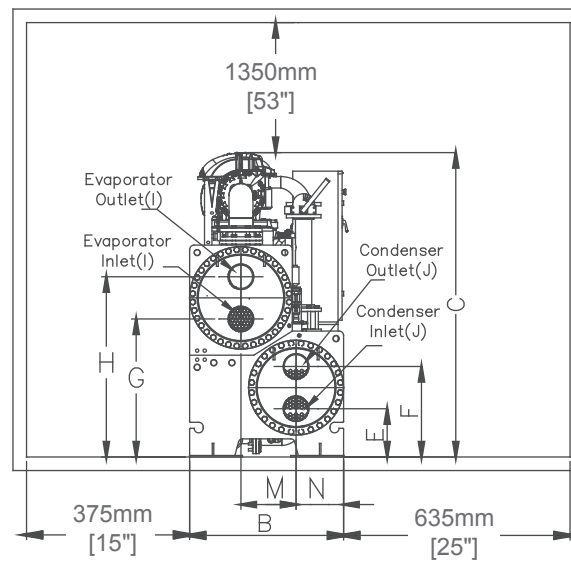

Model	Length "A"	Width "B"	Height "C"	Clearance For Tube Cleaning "D"	E	F	G	H	M	N	Condenser Water Conn. "J"	Evaporator Water Conn. "I"
	mm [inch]											
AP.EDMD240NDE	4070 [160.0]	1100 [43.2]	2020 [79.5]	3400 [133.9]	323 [12.7]	603 [23.7]	906 [35.7]	1209 [47.6]	365 [14.4]	315 [12.4]	6" NPS	8" NPS
AP.EDMD300NEE	3890 [153.0]	1210 [47.7]	2140 [84.3]	3400 [133.9]	330 [13.0]	679 [26.7]	988 [38.9]	1337 [52.6]	400 [15.7]	380 [15.0]	8" NPS	8" NPS
AP.EDMD400NGE	4220 [165.9]	1210 [47.7]	2140 [84.3]	3400 [133.9]	330 [13.0]	679 [26.7]	988 [38.9]	1337 [52.6]	400 [15.7]	380 [15.0]	8" NPS	8" NPS

- Notes: 1) Above dimensions are based on standard unit, with 2 passes evaporator and condenser, 1.0MPa [150psi] water side service pressure, left hand side water piping connection (view from control panel).  
 2) Unit layout shown are for a reference. Same orientation may vary.  
 3) Certified drawings are available upon request.

# DIMENSIONS

## Unit Dimensions

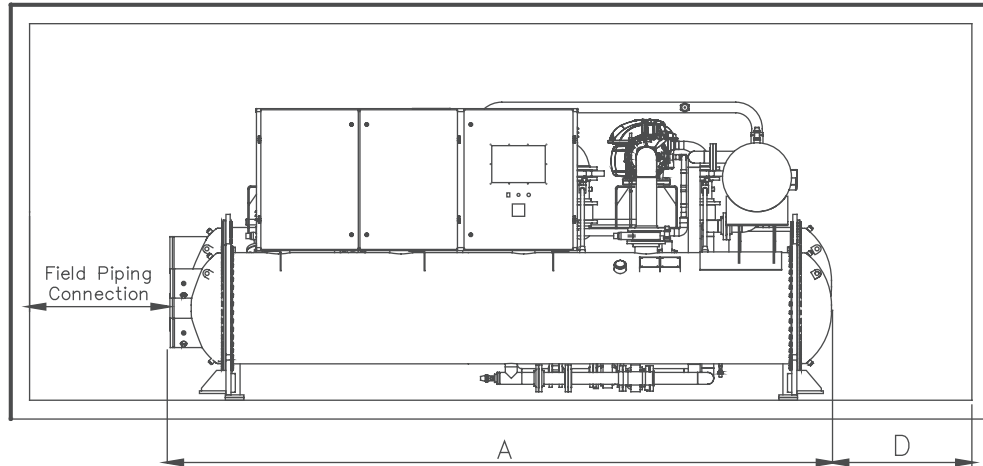

## Three & Four Compressors

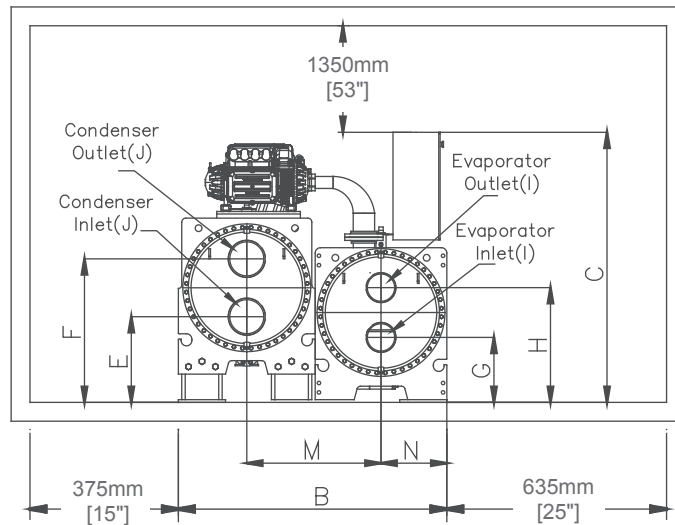

Model	Length "A"	Width "B"	Height "C"	Clearance For Tube Cleaning "D"	E	F	G	H	M	N	Condenser Water Conn. "J"	Evaporator Water Conn. "I"
	mm [inch]											
AP.EDMD450NEU	4330 [170.5]	1920 [75.3]	2080 [81.8]	3800 [149.6]	570 [22.4]	940 [37.0]	435 [17.1]	805 [31.7]	866 [34.1]	400 [15.7]	8" NPS	8" NPS
AP.EDMD600NGU	4390 [172.6]	2050 [80.6]	2190 [86.2]	3800 [149.6]	635 [25.0]	1005 [39.6]	535 [21.1]	905 [35.6]	983 [38.7]	464 [18.3]	8" NPS	8" NPS
AP.EDMD800NGG	4950 [194.7]	2120 [83.3]	2210 [87.0]	4300 [169.3]	637 [25.1]	1067 [42.0]	483 [19.0]	853 [33.6]	1041 [41.0]	489 [19.3]	10" NPS	8" NPS

- Notes: 1) Above dimensions are based on standard unit, with 2 passes evaporator and condenser, 1.0MPa [150psi] water side service pressure, left hand side water piping connection [view from control panel].  
 2) Unit layout shown are for a reference. Same orientation may vary.  
 3) Certified drawings are available upon request.

## Foundation Drawing

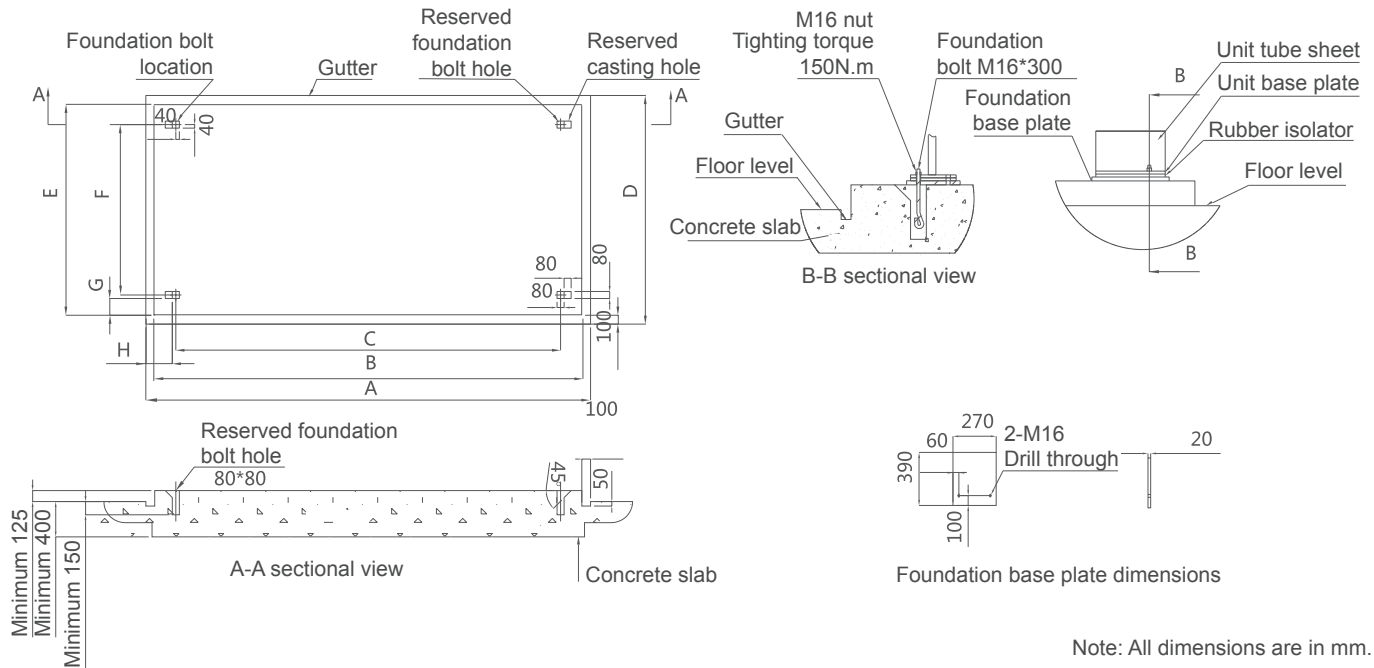

Note: All dimensions are in mm.

Model	A	B	C	D	E	F	G	H
	mm [inch]							
AP.EDMD80NBT	3227 [127.0]	3027 [119.2]	2347 [92.4]	1520 [59.8]	1320 [52.0]	860 [33.9]	190 [7.5]	300 [11.8]
AP.EDMD120NDT	3227 [127.0]	3027 [119.2]	2347 [92.4]	1520 [59.8]	1320 [52.0]	860 [33.9]	190 [7.5]	300 [11.8]
AP.EDMD150NET	3227 [127.0]	3027 [119.2]	2347 [92.4]	1520 [59.8]	1320 [52.0]	860 [33.9]	190 [7.5]	300 [11.8]
AP.EDMD200NGT	3227 [127.0]	3027 [119.2]	2347 [92.4]	1520 [59.8]	1320 [52.0]	860 [33.9]	190 [7.5]	300 [11.8]
AP.EDMD240NDE	4403 [173.3]	4203 [165.5]	3523 [138.7]	1520 [59.8]	1320 [52.0]	860 [33.9]	190 [7.5]	300 [11.8]
AP.EDMD300NEE	4433 [174.5]	4233 [166.7]	3553 [139.9]	1660 [65.4]	1460 [57.5]	1000 [39.4]	190 [7.5]	300 [11.8]
AP.EDMD400NGE	4433 [174.5]	4233 [166.7]	3553 [139.9]	1660 [65.4]	1460 [57.5]	1000 [39.4]	190 [7.5]	300 [11.8]
AP.EDMD450NEU	4711 [185.5]	4511 [177.6]	3831 [150.8]	2379 [93.7]	2179 [85.8]	1719 [67.7]	190 [7.5]	300 [11.8]
AP.EDMD600NGU	4711 [185.5]	4511 [177.6]	3831 [150.8]	2439 [96.0]	2239 [88.1]	1779 [70.0]	190 [7.5]	300 [11.8]
AP.EDMD800NGG	5247 [206.6]	5047 [198.7]	4367 [171.9]	2463 [97.0]	2263 [89.1]	1803 [71.0]	190 [7.5]	300 [11.8]

Notes:

- Unit vibration is very low; generally foundation bolts are not required, unit can be installed directly on the foundation.
- When installation on foundation bolts is required, customer to supplies 4 nos of M16\*300 foundation bolts and foundation base plates.